



E-ISSN: 2707-8051  
P-ISSN: 2707-8043  
IJMTE 2023; 4(1): 01-08  
Received: 01-11-2022  
Accepted: 17-12-2022

**Bekir Cirak**  
Department of Mechanical  
Engineering, Faculty of  
Engineering, Karamanoglu  
Mehmetbey University,  
Yunus Emre Kampus  
Karaman, Turkey

**Corresponding Author:**  
**Bekir Cirak**  
Department of Mechanical  
Engineering, Faculty of  
Engineering, Karamanoglu  
Mehmetbey University,  
Yunus Emre Kampus  
Karaman, Turkey

## Micro controller based spherical sun power generator for photovoltaic energy

**Bekir Cirak**

### Abstract

In this study, the reflection of the sun rays directly on the spherical lens and its focusing in this lens is examined. Energy collection efficiency of such a spherical surface has been analyzed. Compared with traditional sun fixed panel and sun tracker panel. An experimental device is made to test the solar intake from all directions, including scattering and reflections from spherical lenses. In order to obtain maximum energy from spherical lens, a microcontroller based spherical lens system has been developed that takes into account both solar azimuth and altitude angles. Thus, the sun was monitored on the spherical lens based on real time data. The control unit used in this study was the PIC AT89C51 microprocessor and LM 2596 integrated circuit with real time clock. A program that instantly calculates the sun's movements (azimuth and elevation angles) using the solar geometry throughout the day and year was loaded on the PIC. The angle values calculated by this program were converted into pulse width modulation signals and the spherical lens system was controlled using these signals. As a result of the experiments, it was observed that more energy was obtained by using a microcontroller-based spherical lens system. In addition, a low cost and easily programmed control system has been obtained that monitors the sun in real time, ensures stable operation of the system and consumes very little energy.

**Keywords:** Spherical lens, microcontroller (PIC), photosensitive, renewable energy

### 1. Introduction

Solar energy is the most energy source in the world. The sun is the world's main energy source. Most renewable energy sources, such as wind and ocean waves, are caused by the sun. Currently, photovoltaic (PV) based solar panels have been in commercial use for some time. PV module formation started with hard silicon solar cells. For this reason, there are technological advantages and innovations in the production and installation of flat panel solar panels. In the early 2000s, futurist Ray Kurzweil stated that with solar technology, it can meet all energy needs of the world in 20 years. He said that the amount of energy the Earth received in just one hour would be enough to make people's lives easier for a year.

German architect Andre Broessel, who thinks a lot about the insufficiency of the sun, invented a model, spherical lens device, designed to overcome the existing bottlenecks of technology. Basically, the Spherical lens concept is not a radical move from other panel technologies. Because it says solar cells are used to collect sunlight and more juice can be squeezed from the sun. It is the biggest sustainable energy source of the sun in the world. For more than 40 years, energy studies have been working to bring this resource to the first place. The problem is low efficiency: 80% of PV panels installed worldwide have up to 15% performance; however, if the panels do not watch the sun, the average annual slope losses increase by 70%.

According to Broessel, the conversion of light into energy can be optimized all year round, even in bad weather. It is unrealistic to think that energy efficiency can be doubled in a year. The conversion of light into energy can be optimized year-round, even in bad weather. Today, solar panels have revealed the need for designs that will reduce the cost of the system, facilitate the control of the system and increase the amount of electrical energy obtained from the system. Some studies on the subject can be mentioned in the literature; Al Mohammad presented a solar tracking design so that the motion of a photovoltaic module was controlled to track solar radiation using a programmable logic controller (PLC) unit <sup>[1]</sup>. Abdallah and Nijmeh have developed an PLC controlled open loop type solar tracking system <sup>[2]</sup>. Barakat *et al.* has designed a two-axis solar tracking system that operates with a closed circuit system and controlled by electronic circuits <sup>[3]</sup>.

Chong and Wonga presented the most general form of sun-tracking formula that embraces all the possible on-axis tracking methods. The general sun-tracking formula not only can provide a general mathematical solution, but more significantly it can improve the sun-tracking accuracy by tackling the installation error of the solar collector [4].

Wang *et al.* presented an electromechanical, two axes sun tracking system based on single chip microcomputer (MCU) [5].

Abu Khader *et al.* carried out an experimental investigation on the effect of using multi-axes sun-tracking systems on the electrical generation of a flat photovoltaic system (FPVS) in Jordan. In this study, multi axes (N-S, E-W, vertical) electromechanical sun-tracking system was designed and constructed. The measured variables were compared with that at fixed axis. It was found that there was an overall increase of about 30–45% in the output power for the North–South axes (N-S) tracking system compared to the fixed PV system [6].

Rubio *et al.* presented a control application of a sun tracker that is able to follow the sun with high accuracy without the necessity of either a precise procedure of installation or recalibration. A hybrid tracking system that consists of a combination of open loop tracking strategies based on solar movement models and closed loop strategies using a dynamic feedback controller is presented. Energy saving factors are taken into account, which implies that, among other factors, the sun is not constantly tracked with the same accuracy, to prevent energy overconsumption by the motors. Simulation and experimental results with a low cost two axes solar tracker are exposed, including a comparison between a classical open loop tracking strategy and the proposed hybrid one [7]. Khalifa performed an experimental study to investigate the effect of using a two axes sun tracking system on the thermal performance of compound parabolic concentrators (CPCs). The tracking CPC collector showed a better performance with an increase in the collected energy of up to 75% compared with an identical fixed collector [8].

Oner *et al.* conducted a study on a two axes sun tracking system and obtained a higher performance [9].

Sungur implemented a single-axis (azimuth angle) sun tracking system with PLC control and obtained 32.5% more energy from the PV panels which track the sun compared to the PV panels at fixed positions [10]. Also a PLC controlled system which tracks the sun on both axes according to azimuth and altitude angles was developed and it was observed that 42.6% more energy was obtained in the two axes sun tracking system when compared to the fixed system [11].

In the present study, a microcontroller based two-axes sun tracking system which tracks the sun on both azimuth and altitude angles and which does not require photo sensors or pyranometers was developed in order to obtain the maximum energy from the sun. The azimuth and altitude angles were calculated by the microcontroller using the data on the latitude and longitude of the location of the PV panel. PWM signals that change based on the values of these angles were produced and used in order to control the actuator motors. The study aims to present information about PV panels and spherical lens systems. Detailed information about the microcontrollers and the program which control the system is presented in the third section.

The experimental results obtained through the suggested system are presented.

## 2. Photovoltaic energy

Photovoltaic cells are devices that generate electricity from direct solar energy, which is among the renewable energy sources. They are produced in different sizes and different strengths. The power available is increased by connecting the panels in series or in parallel. The most important reason to prefer solar cells is that they benefit from a source that can be considered as infinite and do not create waste materials. However, filling these cells with full capacity is also an important issue, since the angle of incidence of solar rays in fixed panels is not always 90 degrees. In Sun tracker panels, maintenance and sensitivity of device elements may not be provided completely. As the spherical lens has the feature of focusing and concentrating the sun rays, it produces 40% more energy than the sun tracker system and 70% more than the fixed system [12].

### 2.1 Solar angles

The Earth has two different movements; It revolves around its own axis and revolves around the sun. Due to these movements, the sun's rays come to the earth at two different angles. These are called the azimuth angle and altitude angle [13].

#### 2.1.1 Solar azimuth angle ( $A_s$ )

The angle of the sun's rays with the surface of the earth, from sunrise to sunset, is called the surface azimuth angle (equation 1). The azimuth angle is calculated mathematically for each month, day and hour of the year as follows [14].

$$\cos(a_s) = \frac{\sin(\alpha) \sin(L) - \sin(\delta)}{\cos(\alpha) \cos(L)} \quad (1)$$

where  $L$  is the local latitude ( $^\circ$ ),  $a_s$  the solar azimuth angle ( $^\circ$ ),  $\delta$  the solar declination angle ( $^\circ$ ), and  $\alpha$  the solar altitude angle ( $^\circ$ ). In the Northern hemisphere, the largest solar azimuth angle occurs as  $232^\circ$  on 4th July. The smallest solar azimuth angle in the Northern hemisphere occurs as  $26^\circ$  on 4th July.

#### 2.1.2 Solar altitude angle ( $\alpha$ )

The solar altitude angle ( $\alpha$ ) is defined as the angle between the horizontal plane of the earth's field and a point on the earth (Figure 1). In any period between sunrise and sunset, the solar altitude angle is calculated for each day of the year (Equation (2)). The sun altitude angle at sunrise and sunset time is 0 degrees. The maximum value of the solar altitude angle is the noon hours in all seasons. The solar altitude angle is calculated as follows. [15]:

$$\alpha = \sin^{-1} \left[ \cos(L) \cos(\delta) \cos(h) + \sin(L) \sin(\delta) \right] \quad (2)$$

Where  $\alpha$  is the solar altitude angle ( $^\circ$ ),  $L$  the local latitude ( $^\circ$ ),  $\delta$  the solar declination angle ( $^\circ$ ) and  $h$  the hour angle ( $^\circ$ ). According to the calculations, in the Northern hemisphere in Siirt / Turkey, where the experiment was conducted, the highest value of the solar altitude angle is  $68^\circ$  in the summer months (4 July). The highest value of the

solar altitude angle is 42 in the winter months (December 27).

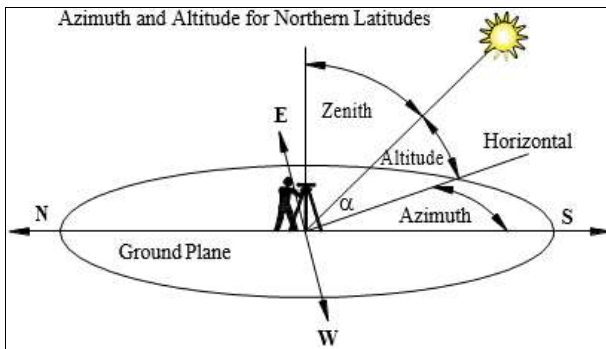

Fig 1: Solar azimuth and altitude angles [15]

**2.2 Spherical sun power generator**

A spherical solar power generator, called spherical lens, was invented. It will produce twice the efficiency of a conventional solar panel in a much smaller surface area. At the same time, this spherical lens incorporates a hybrid collector to convert it into daily electricity and thermal energy. Developed by German architect Andre Broessel, this system charges and stores energy during the day, and can even collect energy from the moon and ambient lights at night. this system used a highly efficient multi-splicing cell.

It reduced the surface of the cell to 1% compared to a conventional silicon cell, provided that it was the most appropriate and equal power output.

The system produces twice the efficiency of a conventional panel. It has smaller cell area and lower carbon footprint. Because its production requires less valuable semiconductor or other building materials. Multi-link cells made of multiple materials respond to multiple light wavelengths, and some of the energy to be lost may be captured and transformed. Multi articular cells can only work with condensing systems. Photovoltaic solar panels are 20-30 percent efficient. Solar radiation is 1000 watts / m2. It has been shown by experiments that the panels that constantly turn to the sun will be more efficient if they are in the form of spheres. It is claimed that it produces 5-6 times more energy because of lensing in spherical lenses. More Light energy falls on the glass or lens surface in the Spherical lens system. [16-17].

Through the movement of the frame following the sun, the sun's rays enter and focus on the spherical lens. Following the focus, the solar panel generates intense solar energy and sends it to the battery. The frame that follows the sun and the solar panel that follows the focus make these movements by means of sensors 1 and 2 - DC 1 motor and 2. Pinion gear is reflected on the solar panel by following the focused rays by rolling on the rack gear. as shown in Figure 2.

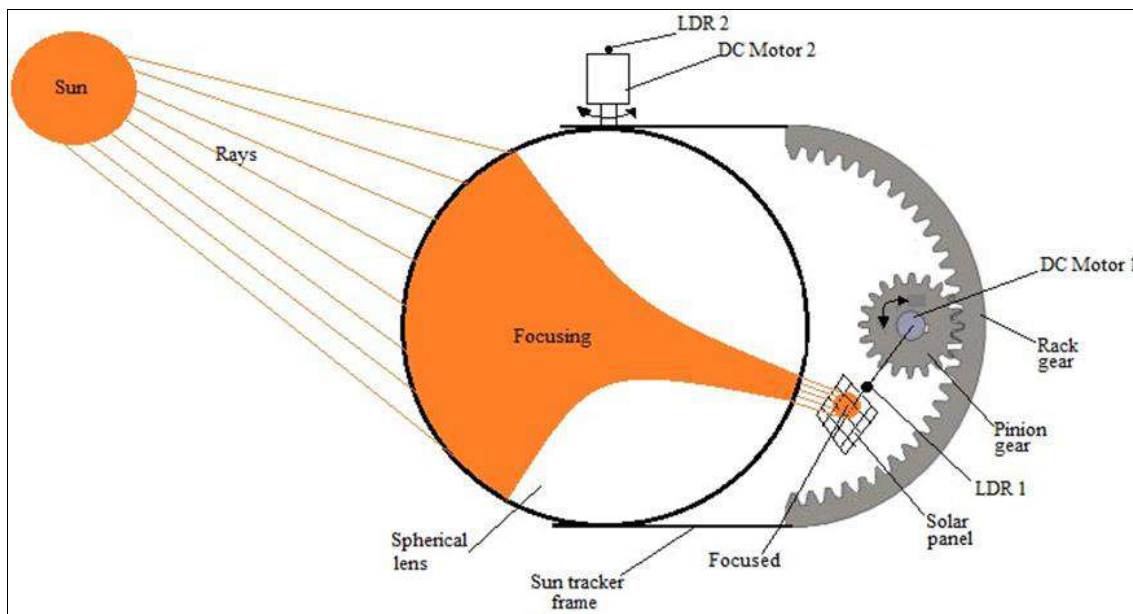

Fig 2: Parts and working principles of spherical sun power generator

The spherical lens power generator converts the rays received from the sun in the daytime to the electrical energy at night, from the ambient lights and from the moon. Thus, the conversion of light into energy can be optimized all year round, even in bad weather.

**2.2.1 Spherical sun power system**

In order to obtain maximum energy from the spherical lens, the sun's rays must fall vertically on the panel. For this purpose, spherical lens systems have been developed. Spherical lens systems consist of three main parts:

1. Sensors that detect the position of the sun or determine the position of the sun by calculating the solar geometry

2. Control systems that produce the necessary control signals by evaluating the signals or calculation results from the sensors
3. Motor providing the necessary mechanical power to the drive circuits of the sphere frame following the focus and the sun following the sun.

Various disruptors occur during the application of these systems. Photosensor monitoring systems require the use of 2 different photosensors for biaxial monitoring applications. Also, instability occurs when one of the sensors is blocked or the weather is partly cloudy.

Different control elements are used in control systems such as PIC, PLC and other similar elements. Each of these



control elements has specific programming methods. In mechanical systems, the drive is selected based on the motor type (DC motor, Step motor). The working principles of the motors used in the system prevent to obtain maximum energy from the sun. For example, in step motors, movement takes place in steps. Although solar rays initially fall vertically onto the panel, maximum energy cannot be obtained from step motorized systems because the solar azimuth angle changes during the time until step changes occur. In DC motors, a separate circuit must be used to

change the direction [18-19]. Due to the negative aspects and results presented above, an actuator motor that can monitor instant changes in the angles of the sun and change the position and angle of the system according to the control signals is used in this study. Depending on the movement and direction of rays in the morning and afternoon, the frame performs the motive 1 of the spherical lens. Depending on the focus of the rails, the focused viewer moves from the motion of the rack gear with the rack gear. This situation is shown in Figure 3.

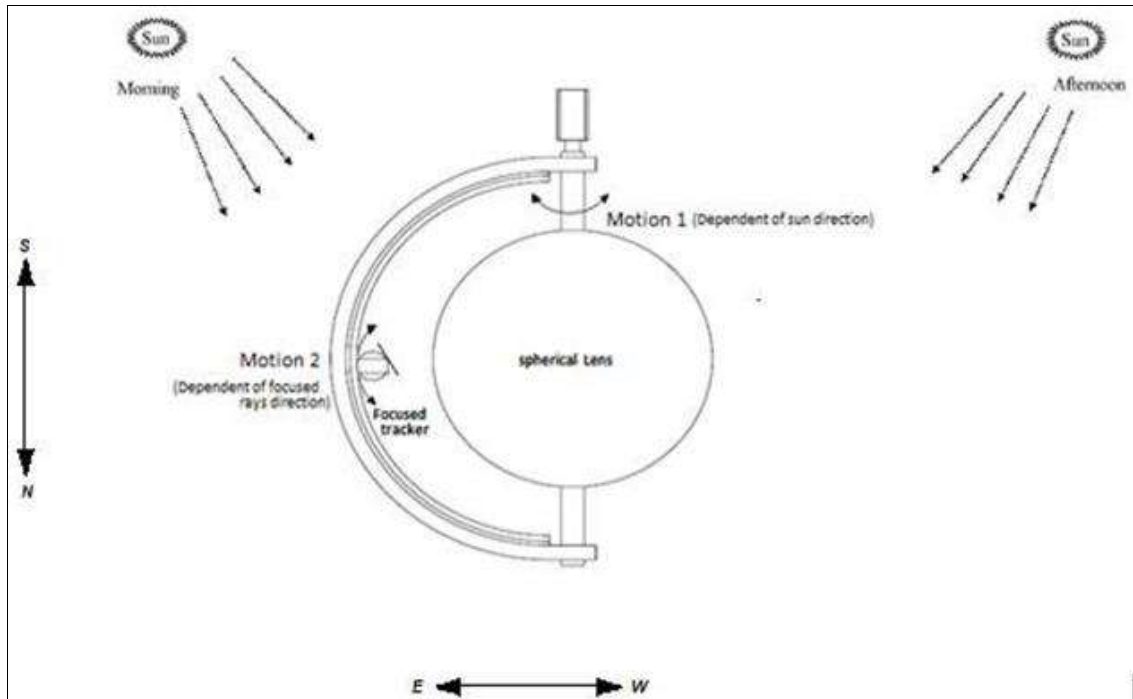

Fig 3: Motions and position of spherical sun power system in the morning and afternoon

**2.2.2 Spherical material**

In this study, used spherical lens specification by model: optical ball lens, material: glass (none coating), shape: ball, structure: spherical, diameter: 0.5-150 mm. Fig.4 shows spherical lens.



Fig 4: Spherical Ball Lens [20]

Ball lenses are great optical components for improving signal coupling between fibers, emitters and detectors. They are also used in endoscopy, bar code scanning, ball pre-forms for aspheric lenses and sensor applications. Ball lenses are manufactured from a single substrate of glass and can focus or collimate light, depending upon the geometry oh the input source. They are commonly used for laser

collimating and focusing, laser to fiber coupling, fiber to fiber coupling and fiber to detector coupling. Larger spheres are easier to handle ease the sensitivity of translational alingment. However smaller spheres has the benefit of fitting into smaller packages [20].

**2.2.3 Spherical cells**

More Light energy falls on the glass or lens surface in the Spherical lens system. Rawlemon mini cells are only% 1 the size of a conventional pv module [21]. This situation is shown in Fig.5.

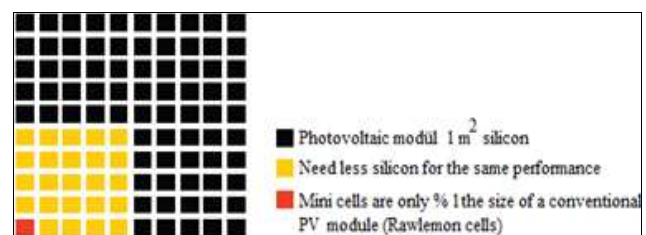

Fig 5: Comparasion spherical cell between conventional cells

**3. Control circuits**

In the control of a servo motor, a circuit PIC (Peripheral Interface Controller) AT 89C51 microcontroller, breadboard, jumper cables, 8 MHz crystal, two 10 kΩ resistors, two 22 pF capacitors and a digital push button are used. Also,

- Analog-digital convector
- DC motor card
- DC motor
- Digital Alarm Clock
- Digital Counter
- Digital Frequency and Energy Meter LCD display
- Gear system Motion Sensor

The circuit diagram of the control system is shown in Figure 6. The motors are represented by coils and only the actuator motor's control signal is displayed. The operating voltage is

not displayed as it has a solar panel at 24 V. The circuit diagram is designed using labels instead of wiring to provide a simple look. The modules were connected to a bridge circuit very similar to the Wheatstone bridge. Their research shows for tracking system, unlike the fixed modules, the voltage output in the evening and morning are not very different and the tracking mode collects 30% more energy. Spherica lenses collect more energy than these traditional two systems. Spherical lens system is 40% more efficient than sun tracker systems [22-23].

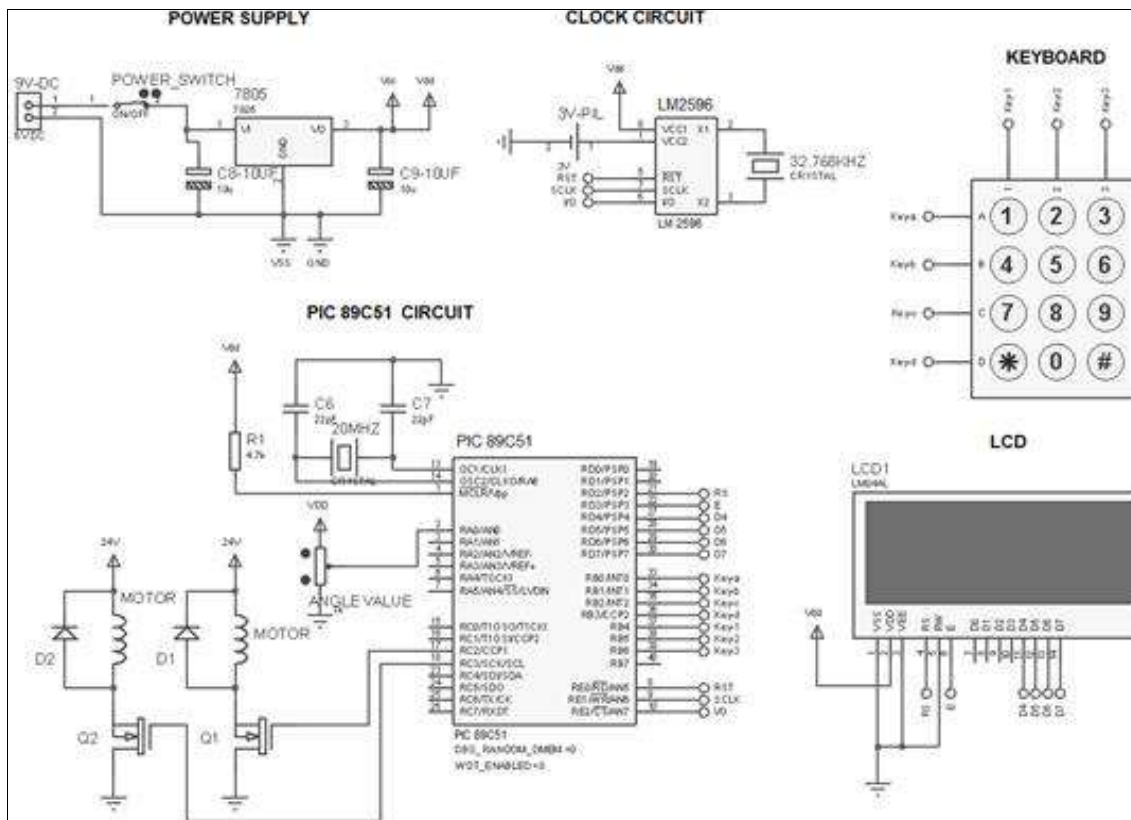

**Fig 6:** Circuit diagram of the control system

Direction control of a DC motor is very simple; just reverse the polarity, means every DC motor has two terminals out. When we apply DC voltage with proper current to a motor, it rotates in a particular direction but when we reverse the connection of voltage between two terminals, motor rotates in another direction. The direction control of DC motor is presented in Figure 7.

focused tracker axes, pins which were fixed to the frame and pinion gear which were connected to the pins of the actuator motors were used. The supply voltage of these actuator motors was 24 V DC and the control voltage was 2–10 V DC. The memory capacity and certain important characteristics of the PIC 89C51 microcontroller used in the designed system. The PIC 89C51 microcontroller have all the necessary characteristics required for controlling the designed PV panel.

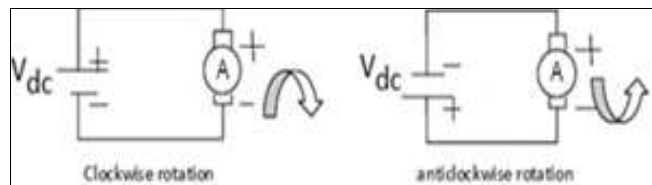

**Fig 7:** Direction control of DC motor

In the present study, LXR-190 model (amorphous silicon) solar panels and BK7 model (UV fused silica) Spherical Lens (35 mm diameter) were used for conducting the experiments. The characteristics of the LXR-190 model PV panels are nominal power  $P_{max}$ , 65 [Wp], nominal current [1.00 A], nominal voltage 70 [V], short circuit current 1.20 [A], AM=1.5, E=1100 W/m, T=30 oC. The solar panels on

The LM 2596 integrated circuit was used in the system because real time clock (RTC) information can be obtained, the circuit has a 45 byte RAM and it communicates with the microprocessor through a serial interface. The energy consumption of the LM 2596 integrated circuit is low since it can operate at voltages between 2.0 V and 5.0 V and consumes a current less than 300 nA at 2.0 V. Furthermore, another important reason for using the circuit in the system was that it can operate between temperatures of  $-45\text{ }^{\circ}\text{C}$  and  $+75\text{ }^{\circ}\text{C}$ . The LM 2596 has two different power supply pins (VCC1, VCC2). Even if energy is not supplied to the system through a battery connected to one of these pins, the LM 2596 continues to keep the hour and time information in its memory. The block diagram of the system designed for

moving the solar panel in real time is presented in Figure 8. In the designed system, the date and time information was collected in real time and transferred to the PIC 89C51 microprocessor by using the LM 2596 integrated circuit. The values read by the LM 2596 integrated circuit were also displayed on the LCD screen. A keypad was used in the circuit to set a password in order to provide the security of the system.

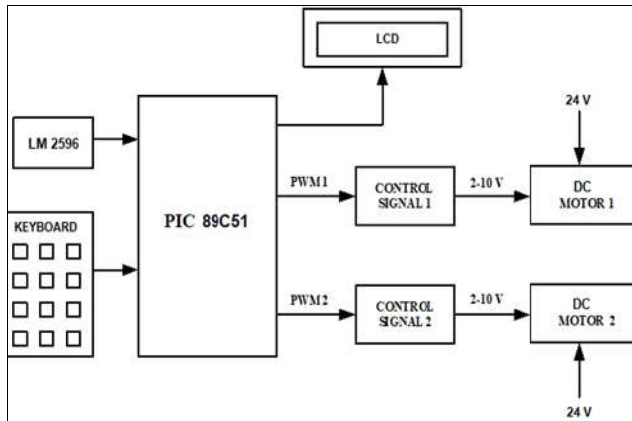

Fig 8: The design control system

The flow diagrams of microcontroller and the flow diagram of the programmable integrated circuit are shown in Figure 9. When the system is used for the first time, the user is asked to set a password on the LCD screen. The program asks the user to enter the four-digit password again and the password is activated when it is retyped. The system requires this password when it is operated again later. The date and time data was read from the LM 2596 and azimuth and slope angles were calculated by using the program the flow diagram. Two PWM signals were produced by the PIC

89C51 based on the calculated values of the azimuth and slope angles. Voltages of 2-10V, which is the control signal of the motors, were obtained through driving with PWM signals and using the motors, the PV panel was rotated by the angle specified.

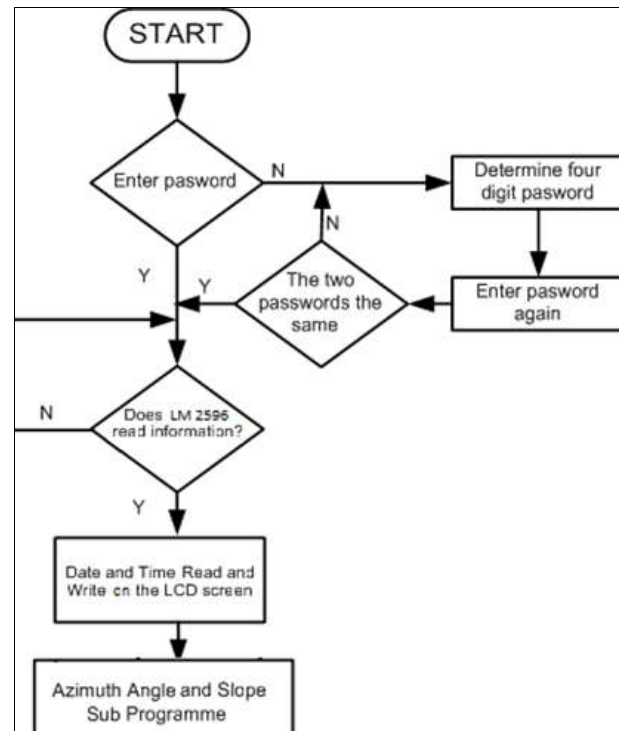

Fig 9: Algorithm of the microcontroller

In the designed system, the spherical lens was rotated according to the azimuth and the slope angles. The block diagram of this system is presented in Figure 10.

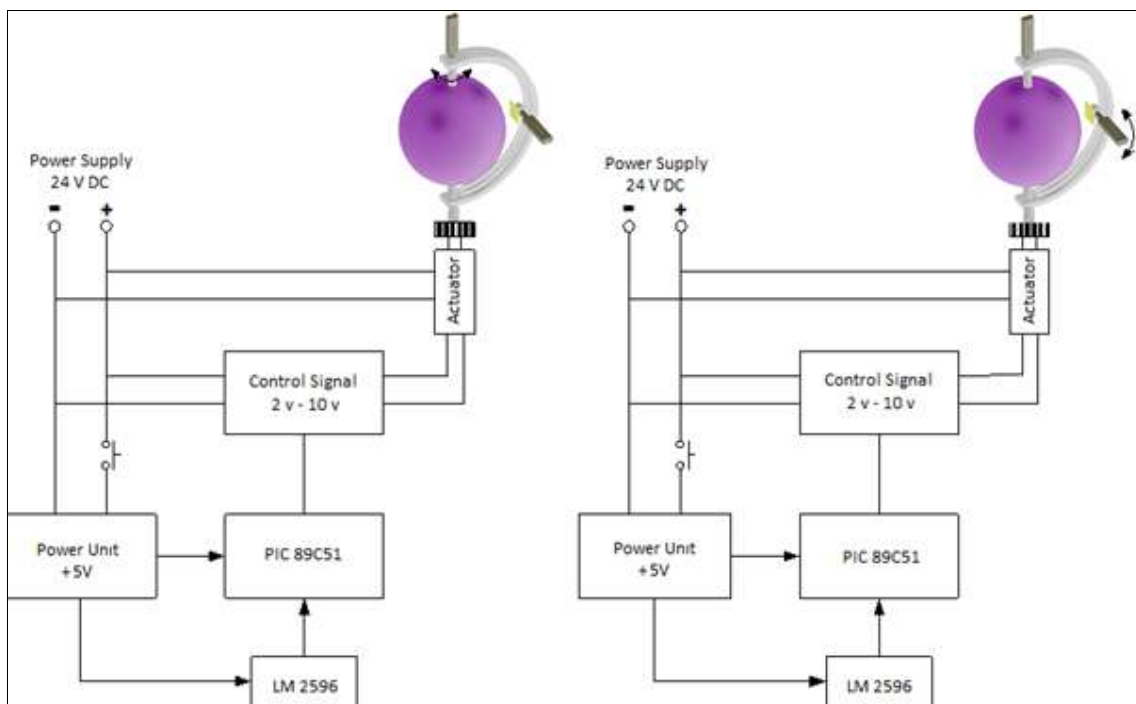

Fig 10: Block diagram of the two-axes movement of the PV panel

**3.1 LDR (Photo Resistor)**

LDR is a light sensitive circuit element. It has a working principle inversely proportional with the light intensity

falling on it. As the light intensity decreases, its resistance value decreases and as the light intensity increases, the resistance value increases. LDRs act as a switch by

changing their resistance values. If we look at it from another angle, they also function as an optical sensor. They deteriorate under extreme temperatures (Maximum: 65 °C). The control of the M motor with LDR is shown in Figure 11.

Although LDR is a kind of resistance, it is also a passive sensor. It controls the ambient light and triggers the electrical circuit to which it is connected. If LDR is used in a circuit or system, it should be understood that a photosensitive response has occurred or the light level has been checked. The LDR initial principle is presented in Figure 12 [24-25].

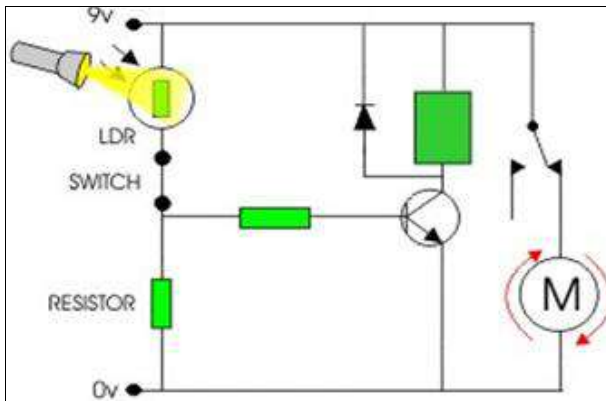

Fig 11: Control of M motor with LDR

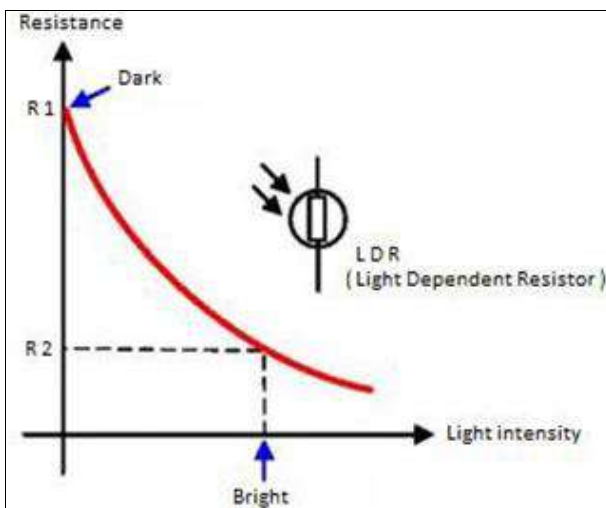

Fig 12: LDR runing principle

**4. Experimental results**

The spherical lenses designed in this study, 41.7 ° latitude in the northern hemisphere was tested in Turkey's Siirt. Calculations were made for the province of Siirt. The average amount of energy obtained from all three systems in Siirt and the power usage times during the day hours are shown in Figure 13. In this graph, it is seen that the province of Siirt uses solar energy for an average period of 10 hours. Since solar energy cannot be collected from the PV panel after this 10 hour period, the PV panels of the fixed and sun tracker systems are brought to zero position and the system goes into standby mode until the sun rises. In this way, it is aimed to save energy and reduce mechanical fatigue and wear. However, the situation of the spherical lens system is different here. Because the spherical lens system receives energy from the moon and ambient lights at night. and it

charges the battery as focused and concentrated energy. For this reason, there is no standby mode in the spherical lens. The voltage and power change values obtained as a result of the movement of the PV panel with the sensor-based classical method and the voltage and power change values obtained by rotating the panel were compared by calculating the azimuth and slope angles without the need for sensors. Also, the total voltage and power change values of the day and night obtained from the spherical lens are included in this comparison. In Figure 13, it can be seen that using the spherical lens system, more voltage is generated and more power is obtained than the conventional two systems. Under equal conditions, the fixed system converts the energy from the sun to 55 w and the Sun tracker system to 65 w, while the spherical system generates 80 w.

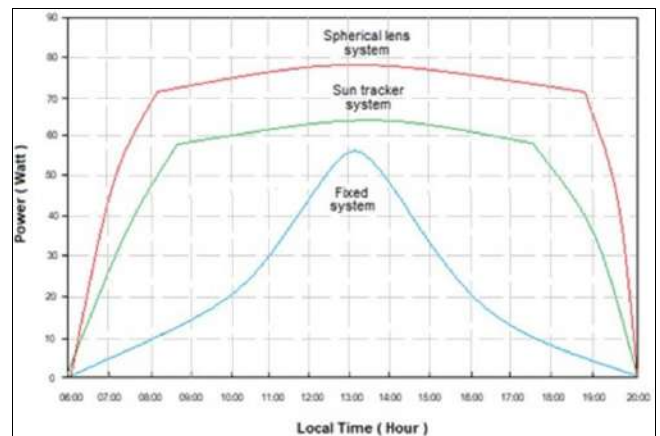

Fig 13: Energy comparison of fixed – sun tracker – spherical lens systems

Comparison of power values between fixed sytem, sun tracker and spherical lens sytem is shown in Fig 13. In the city of Siirt in Turkey, data were collected from the sun between the hours of 06:00 and 20:00 on July 4, 2020. These data were taken for fixed, sun tracker and spherical lens systems. Data were read in 3 systems at the same time. and the graph curve ie the comparison curve Fig.12. It was formed. In this study, controlling the spherical lens system with micro controller constituted the main study. The comparison of power values between fixed sytem, sun tracker and spherical lens sytem is shown in Fig 13. In the city of Siirt in Turkey, data were collected from the sun between the hours of 06:00 and 20:00 on July 4, 2020. These data were taken for fixed, sun tracker and spherical lens systems. Data were read in 3 systems at the same time and the graph curve ie the comparison curve Fig.13. It was formed. In this study, controlling the spherical lens system with a micro controller constituted the main study.

**5. Conclusion**

In this study, a spherical solar generator system has been developed that monitors the sun in real time at both azimuth and altitude angles and does not require photo sensors. Developed as a system microcontroller based spherical solar generator system, tested in the Turkey's Siirt and the sun with the developed spherical lens system, according to a fixed system and a tracker system has been shown to obtain more energy. Using the system developed in this study, the sun was monitored in real time, regardless of whether the weather was clear or cloudy, day and night. Under the same



conditions, for each of the three systems, between the hours of 06:00 and 20:00 on July 4, 2020, each system has its own measurement. Since the monitoring was carried out in real time, no change in the energy obtained was observed. Spherical system, on the other hand, produced more power than sun tracker system. Compared to the stationary system that produces 55 watts of energy, the solar tracking system produced 65 watts of energy. This redundancy is that it absorbs rays from the sun up to 90° using the alpha angle perpendicular to the sun. The spherical system produced more power than the solar tracking system. This value is 80 watts. The reason for this excess is that it takes intense focus by focusing on the rays coming from the sun. When proportional calculation is made here, it is seen that the spherical lens system achieves 70% more energy than the fixed system and 20% more energy than the sun tracker system.

Nomenclature	
$a_s$	solar azimuth angle
$\alpha$	solar altitude angle
L	local altitude
$\delta$	solar declination angle
$h_s$	hour angle
E	irradiation
T	temperature
V	voltage
A	current
$W_p$	peak watt (w)
PIC Peripheral Interface Controller	

## 6. References

- Al-Mohamad A. Efficiency Improvements of Photovoltaic Panels using a Sun Tracking System. *Applied Energy*. 2004;79:345-354.
- Abdallah S, Nijmeh S. Two Axes Sun Tracking System with PLC Control. *Energy Convers Manage*. 2004;45:1931-1939.
- Barakat B, Rahab H, Mohmedi B, Naiit N. Design of a Tracking System to be used with Photovoltaic Panels, Fourth Jordanian International Mechanical Engineering Conference (JIMEC); c2001. p. 471-488, [in Arabic].
- Chong KK, Wonga CW. General formula for on-axis sun-tracking system and its application in improving tracking accuracy of solar collector. *Solar Energy*. 2009;83:298-305.
- Wang Q, Zhang J, Hu R, Shao Y. Automatic Two Axes Sun-Tracking System Applied to Photovoltaic System for LED Street Light, In: *Applied Mechanics and Materials*, Chen L, Zhang Y, Feng A, Xu Z, Li B, Shen H (Eds.). 2010;43:17-20.
- Abu-Khader MM, Badran OO, Abdallah S. Evaluating multi-axes sun-tracking system at different modes of operation in Jordan. *Renewable and Sustainable Energy Reviews*. 2008;12:864-873.
- Rubio FR, Ortega MG, Gordilloa F, López-Martínez M. Application of new control strategy for sun tracking, *Energy Conversion and Management*. 2007;8:2174-2184.
- Khalifa AN, Al-Mutwalli SS. Effect of Two-Axis Sun Tracking on the Performance of Compound Parabolic Concentrators. *Energy Conversion and Management*. 1998;39:1073-1079.
- Oner Y, Cetin E, Yilanci A, Ozturk HK. Design and Performance Evaluation of A Photovoltaic Sun-Tracking System Driven by A Three-Freedom Spherical Motor. *Int J Energy*. 2009;6:853-867.
- Sungur C. Multi-Axes Sun-Tracking System with PLC Control for Photovoltaic Panels in Turkey. *Renew Energy*. 2009;34:1119-1125.
- Sungur C. Sun-Tracking System with PLC Control for Photo-Voltaic Panels. *Int J Green Energy*. 2007;4:635-643.
- Yelmen B, Cakir MT. Total for the horizontal surface of the city of Siirt solar radiation comparison of predicted and test values. *Energy Educ Sci Technol Part A*. 2011;28:211-s220.
- Wengenmayr R, Bührke T. (Eds.) *Sustainable Energy Concepts for the Future*, Book Review. *Renewable Energy, Environmental Engineering and Management J*. 2008;7:355-358.
- Parkin RE. Solar angles revisited using a general vector approach. *Solar Energy*. 2010;84:912-916.
- Naing LP, Srinivasan D. Estimation of solar power generating capacity, 11th International Conference on Probabilistic Methods Applied to Power Systems (PMAPS); c2010. p. 95-100.
- Ozbalta TG, Ozbalta N. Theoretical and experimental analysis of the solar energy gain of transparent insulated external wall in climatic conditions of Izmir. *Energy Educ Sci Technol Part A*. 2010;25:69q-86.
- Partain LD, Fraas LM. *Solar Cells and Their Applications*, John Wiley and Sons; c2010.
- Mpoweruk. [http://www.mpoweruk.com/solar\\_power.htm](http://www.mpoweruk.com/solar_power.htm) (Last Accessed Date: 14.04.2010)
- Kelly NA, Gibsons TL. Improved photovoltaic energy output for cloudy conditions with a solar tracking system. *Solar Energy*. 2009;83:2092-2102.
- <https://kristinarustphotography.com/5-tips-for-lens-ball-photography/>
- Wen-tian H, Jin-ping L. Research and Design of Intelligent Temperature Control System, Second International Workshop on Education Technology and Computer Science. 2010;1:538-541.
- Luque A, Hegedus S. *Handbook of Photovoltaic Science and Engineering*, John Wiley & Sons, Inc, USA; c2002.
- Vişa I, Diaconescu DV, Dinicu (Popa) MV, Burduhos BG. Quantitative Estimation of the Solar Radiation Loss in Braşov Area. *Environ Eng Manage J*. 2009;8:843-847.
- Eliyi DT, Caylan T, Eliyi U. Economic and environmental viability analysis for a photovoltaic-powered led system in tunnel illumination. *Energy Educ Sci Technol Part A*. 2011;27:233-248.
- Camdali U. Economic analysis of photovoltaic systems for household applications in Turkey. *Energy Educ Sci Technol Part A*. 2010;24:125-135.